

W806 MCU Chip Specifications

V2.0

Beijing Lianshengde Microelectronics Co., Ltd. (Winner Micro)

Address: 18th Floor, Yindu Building, No. 67, Fucheng Road, Haidian District, Beijing

Tel: +86-10-62161900

Website: www.winnermicro.com

Document modification record

| Version | revision time | revision history | author | audit |
|---------|---------------|-------------------------------------|--------|-------|
| V1.0 | 2021/2/25 | Create document | Ray | |
| V2.0 | 2021/7/14 | Add Wakeup PIN, Update PIN location | Ray | |
| | | | | |
| | | | | |
| | | | | |
| | | | | |
| | | | | |

content

| | |
|--|-----------|
| Document Modification History | 5 |
| 1 Overview | 4 |
| 2 Features | 4 |
| 3 Chip structure | 6 |
| 4 Function description | 6 |
| 4.1 SDIO HOST Controller | 6 |
| 4.2 SDIO Device Controller..... | 7 |
| 4.3 High-speed SPI device controller..... | 7 |
| 4.4 DMA controller..... | 8 |
| 4.5 CLOCK AND RESET | 8 |
| 4.6 Memory Manager..... | 8 |
| 4.7 FLASH Controller..... | 8 |
| 4.8 RSA Encryption Module..... | 9 |
| 4.9 Generic Hardware Cryptographic Module | 9 |
| 4.10 I2C Controller | 9 |
| 4.11 Master/Slave SPI Controller..... | 9 |
| 4.12 UART Controller..... | 10 |
| 4.13 GPIO Controller | 10 |

| | |
|--|----|
| 4.14 Timer | 10 |
| 4.15 Watchdog Controller | 11 |
| 4.16 PWM controller | 11 |
| 4.17 I²S Controller | 11 |
| 4.18 7816/UART Controller | 11 |
| 4.19 PSRAM Interface Controller | 12 |
| 4.20 ADC | 13 |
| 4.21 Touch Key Controller | 13 |
| 5 Pin Definitions | 14 |
| 6 Electrical Characteristics | 17 |
| 6.1 Limit parameters | 17 |
| 7 Package Information | 18 |

1 Overview

The W806 chip is a secure IoT MCU chip. The chip integrates 32-bit CPU processor, built-in UART, GPIO, SPI, SDIO,

I²C, I²S, PSRAM, 7816, ADC, LCD, TouchSensor and other digital interfaces; support TEE security engine, support a variety of hardware

Decryption algorithm, built-in DSP, floating-point arithmetic unit and security engine, support code security permission setting, built-in 1MB Flash memory, support

Firmware encrypted storage, firmware signature, security debugging, security upgrade and other security measures to ensure product security features. Suitable for small appliances, smart

It can be used in a wide range of IoT fields such as home furnishing, smart toys, industrial control, and medical monitoring.

2 Features

• Chip appearance

• QFN56 package, 6mm x 6mm

• MCU Features

• Integrated 32-bit XT804 processor, operating frequency 240MHz, built-in DSP, floating-point arithmetic unit and security engine

• Built-in 1MB Flash, 288KB RAM

• Integrated PSRAM interface, support up to 64MB external PSRAM memory

• Integrated 6-channel UART high-speed interface

• Integrate 4 channels of 16-bit ADC, the highest sampling rate is 1KHz

• Integrate 1 high-speed SPI interface (slave interface), support up to 50MHz

• Integrate a master/slave SPI interface

• Integrate 1 SDIO_HOST interface, support SDIO2.0, SDHC, MMC4.2

• Integrate 1 SDIO_DEVICE, support SDIO2.0, the maximum throughput rate is 200Mbps

• Integrate 1 I²C controller

MCU chip—W806

• Integrated GPIO controller, supports up to 44 GPIOs

• Integrate 5 PWM interfaces

• Integrated 1-way Duplex I 2S controller

• Integrated LCD controller, support 4x32 interface

• Integrate a 7816 interface

• Integrate 15 Touch Sensors

• Safety Features

• The MCU has built-in Tee security engine, and the code can distinguish the secure world/non-secure world

• Integrated SASC/TIPC, configurable security attributes of memory and internal modules/interfaces to prevent non-secure code access

• Enable firmware signature mechanism for secure boot/upgrade

• With firmware encryption function to enhance code security

• Firmware encryption keys are distributed using asymmetric algorithms to enhance key security

• Hardware encryption module: RC4256, AES128, DES/3DES, SHA1/MD5, CRC32, 2048 RSA, true random number

bionic device

• Low Power Mode

• 3.3V single power supply

• Support work, sleep, standby, shutdown working modes

• Standby power consumption is less than 10uA

3 Chip structure

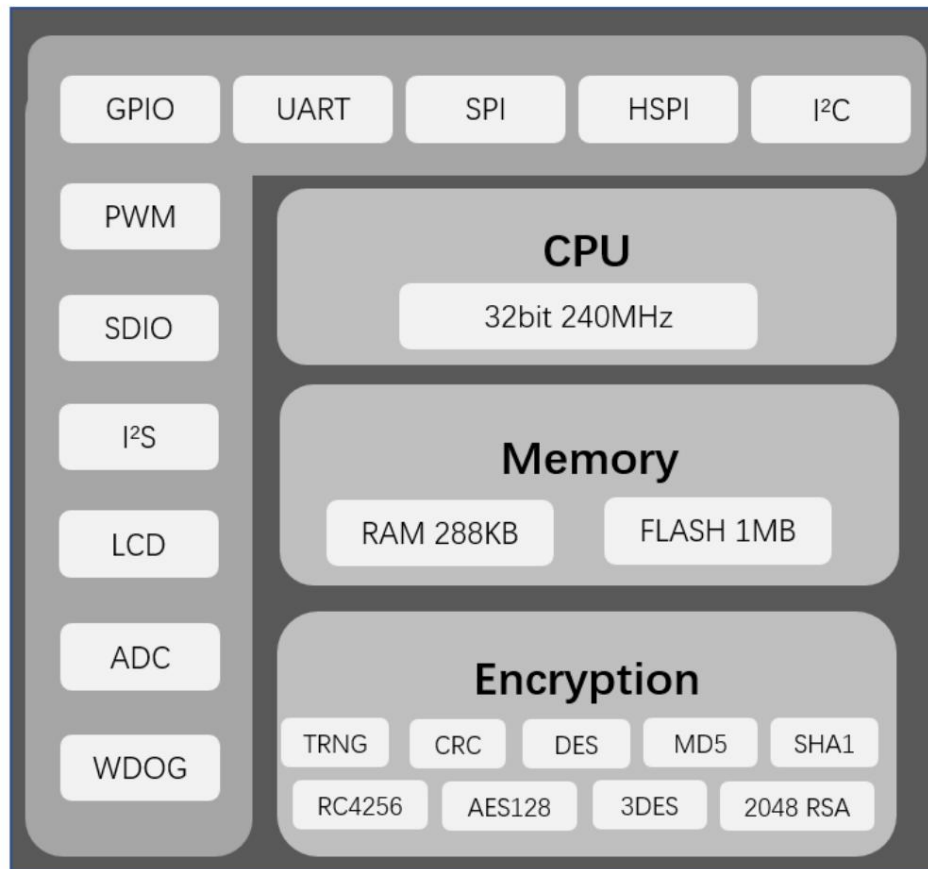

Figure 3-1 W806 chip block diagram

4 Function description

4.1 SDIO HOST Controller

The SDIO HOST device controller provides a digital interface capable of accessing Secure Digital Input Output (SDIO) and MMC cards. were able

Access SDIO devices and SD card devices that are compatible with the SDIO 2.0 protocol. The main interfaces are CK, CMD and 4 data lines.

• Compatible with SD Card Specification 1.0/1.1/2.0(SDHC)

• Compatible with SDIO memory card specification 1.1.0

• Compatible with MMC specification 2.0~4.2

- Configurable interface clock rate, support host rate 0~50MHz
- Support standard MMC interface
- Support blocks up to 1024 bytes
- Support soft reset function
- Automatic Command/Response CRC generation/check
- Automatic data CRC generation/check
- Configurable timeout detection
- Supports SPI, 1-bit SD and 4-bit SD modes
- Support DMA data transfer

4.2 SDIO Device Controller

SDIO2.0 device interface to complete the interaction with the host data. Internally integrated 1024Byte asynchronous FIFO to complete the data between the host and the chip interact.

- Compatible with SDIO Card Specification 2.0
- Support host rate 0~50MHz
- Support blocks up to 1024 bytes
- Support soft reset function
- Supports SPI, 1-bit SD and 4-bit SD modes

4.3 High Speed SPI Device Controller

Compatible with the general SPI physical layer protocol, through the agreed data format for interaction with the host, the host can access the device at high speed, and the maximum supported operating frequency is 50Mbps

- Compatible with general SPI protocol

- ÿ Selectable level interrupt signal
- ÿ Support up to 50Mbps rate
- ÿ Simple frame format, full hardware parsing and DMA

4.4 DMA Controller

It supports up to 8 channels, 16 DMA request sources, and supports linked list structure and register control.

- ÿ Amba2.0 standard bus interface, 8 DMA channels
- ÿ Support DMA operation based on memory linked list structure
- ÿ Software configures 16 hardware request sources
- ÿ Support 1, 4-burst operation mode
- ÿ Support byte, half-word, word operations
- ÿ The source and destination addresses are unchanged or sequentially incremented, configurable or cyclic operation within a predefined address range
- ÿ Synchronous DMA request and DMA response hardware interface timing

4.5 Clock and Reset

Support the control of chip clock and reset system, clock control includes clock frequency conversion, clock shutdown and adaptive gating; reset control includes system and soft reset control of sub-modules.

4.6 Memory Manager

Supports the configuration of sending and receiving buffer size, as well as control information such as the base address of the MAC access buffer, the number of buffers, and the upper limit of frame aggregation.

4.7 FLASH Controller

- ÿ Provide bus access FLASH interface
- ÿ Provide system bus and data bus access arbitration
- ÿ Implement CACHE cache system to improve FLASH interface access speed
- ÿ Provide compatibility with different QFlash

4.8 RSA encryption module

RSA operation hardware coprocessor, providing Montgomery (FIOS algorithm) modular multiplication function. Cooperate with RSA software library to realize RSA algorithm.

128-bit to 2048-bit modulo multiplication is supported.

4.9 General hardware encryption module

The encryption module automatically completes the encryption of the source address space data of the specified length, and automatically writes the encrypted data back to the specified destination address space after completion;

Support SHA1/MD5/RC4/DES/3DES/AES/CRC/TRNG.

- Support SHA1/MD5/RC4/DES/3DES/AES/CRC/TRNG encryption algorithm
- DES/3DES supports ECB and CBC modes
- AES supports ECB, CBC and CTR modes
- CRC supports four modes: CRC8, CRC16_MODBUS, CRC16_CCITT and CRC32
- CRC supports input/output reverse
- SHA1/MD5/CRC supports continuous multi-packet encryption
- Built-in true random number generator, also supports seed to generate pseudo-random numbers

4.10 I2C Controller

APB bus protocol standard interface, only supports master device controller, I²C operating frequency support can be configured, 100K-400K.

4.11 Master/Slave SPI Controller

Supports synchronous SPI master-slave function. Its working clock is the internal bus clock of the system. Its characteristics are as follows:

- Transmit and receive paths each have 8-word deep FIFOs
- The master supports 4 formats of Motorola SPI (CPOL, CPHA), TI timing, macrowire time
- slave supports 4 formats of Motorola SPI (CPOL, CPHA);

- Supports full duplex and half duplex
- The main device supports bit transmission, the maximum supports 65535bit transmission
- The slave device supports transmission modes of various length bytes
- The maximum clock frequency of SPI_Clk input from the slave device is 1/6 of the system clock

4.12 UART Controller

- The device side complies with the APB bus interface protocol
- Support interrupt or polling working mode
- Support DMA transfer mode, there are 32-byte FIFOs for sending and receiving
- Programmable baud rate
- 5-8bit data length, and parity polarity can be configured
- 1 or 2 stop bits configurable
- Support RTS/CTS flow control
- Support Break frame sending and receiving
- Overrun/parity error/frame error/rx break frame
- Up to 16-burst byte DMA operation

4.13 GPIO Controller

Configurable GPIO, software-controlled input and output, hardware-controlled input and output, and configurable interrupt mode.

The GPIOA and GPIOB registers have different starting addresses, but the functions are the same.

4.14 Timer

Microsecond and millisecond timing (the number of counts is configured according to the clock frequency), and six configurable 32-bit counters are realized.

When successful, a corresponding interrupt is generated.

4.15 Watchdog Controller

Support "Watchdog" function. Observe the correctness of software behavior and allow global reset after system crash. "Watchdog" generates a periodic

The system software must respond to this interrupt and clear the interrupt flag; if the interrupt flag has not been cleared for a long time due to a system crash, the

Generate a hard reset to perform a global reset of the system.

4.16 PWM Controller

• 5-channel PWM signal generation function

• 2-channel input signal capture function (two channels of PWM0 and PWM4)

• Frequency range: 3Hz~160KHz

• The maximum precision of the duty cycle: 1/256, the width of the counter inserted in the dead zone: 8bit

4.17 I²S Controller

• Support AMBA APB bus interface, 32bit single read and write operations

• Support master, slave mode, can work in duplex

• Support 8/16/24/32 bit width, the highest sampling frequency is 128KHz

• Support mono and stereo mode

• Compatible with I²S and MSB justified data format, compatible with PCM A/B format

• Support DMA request for read and write operations. Only supports word-by-word operations

4.18 7816/UART Controller

• The device side complies with the APB bus interface protocol

• Support interrupt or polling working mode

• Support DMA transfer mode, there are 32-byte FIFOs for sending and receiving

• DMA can only operate by byte, the maximum 16-burst byte DMA operation

Compatible with UART and 7816 interface functions:

Serial port function:

- Programmable baud rate

- 5-8bit data length, and parity polarity can be configured

- 1 or 2 stop bits configurable

- Support RTS/CTS flow control

- Support Break frame sending and receiving

- Overrun/parity error/frame error/rx break frame

7816 interface function:

- Compatible with ISO-7816-3 T=0,T=1 mode

- Compatible with EVM2000 protocol

- Possible placement guard time (11 ETU-267 ETU)

- Forward/reverse convention is software configurable

- Support send/receive parity check and retransmission function

- Support 0.5 and 1.5 stop bit configuration

4.19 PSRAM Interface Controller

W806 has a built-in PSRAM controller with SPI/QSPI interface, supports external PSRAM device access, and provides bus-based PSRAM read, write, and erase

operate. The maximum read and write speed is 80MHz.

- Support read and write access to external PSRAM

- Configurable as SPI and QSPI

- SPI/QSPI clock frequency can be configured

- Support BURST INC mode access

- Support half sleep mode of PSRAM

4.20 ADC

The acquisition module based on Sigma-Delta ADC completes the acquisition of up to 4 channels of analog signals. The sampling rate is controlled by the external input clock.

It can collect input voltage and also collect chip temperature, and support input calibration and temperature compensation calibration.

4.21 Touch key controller

The basic functions of the module are as follows:

- Supports up to 15 Touch Sensor scans
- Record the scanning result of each Touch Sensor
- Report scan results by interrupt

5 Pin Definition

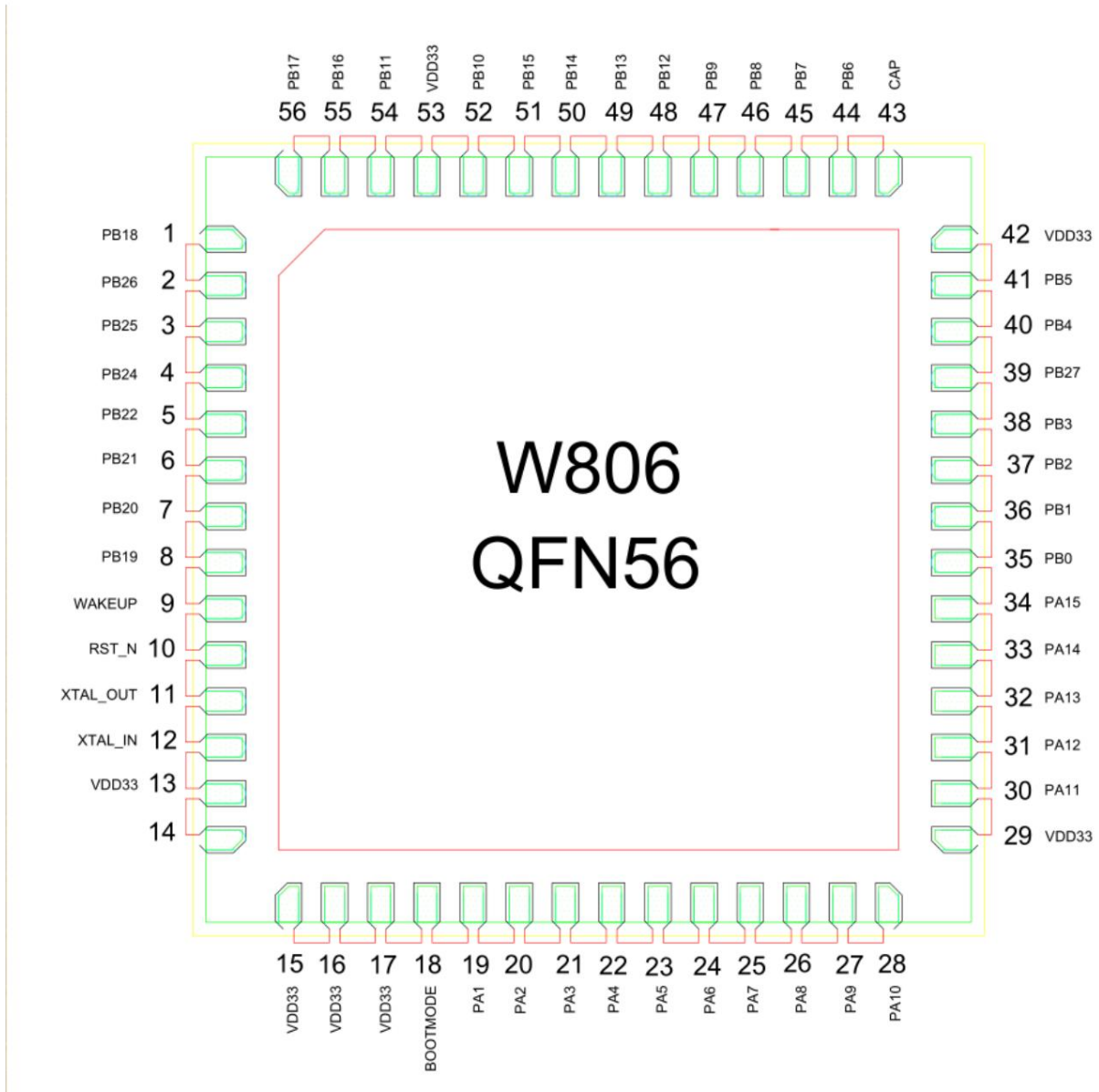

Figure 6-1 Pin layout (QFN32)



Table 6-1 Pin Assignment Definition (QFN56)

| Number | Name | Type | Pin | Function | After Reset | Multiplexing function | Up and down ability |
|--------|----------|------|----------|---------------------------------|-------------|--|---------------------|
| 1 | PB_18 | | | I/O GPIO, input, high impedance | | UART5_TX/LCD_SEG30 | UP/DOWN |
| 2 | PB_26 | | | I/O GPIO, input, high impedance | | LSPI_MOSI/PWM4/LCD_SEG1 | UP/DOWN |
| 3 | PB_25 | | | I/O GPIO, input, high impedance | | LSPI_MISO/PWM3/LCD_COM0 | UP/DOWN |
| 4 | PB_24 | | | I/O GPIO, input, high impedance | | LSPI_CK/PWM2/LCD_SEG2 | UP/DOWN |
| 5 | PB_22 | | | I/O GPIO, input, high impedance | | UART0_CTS/PCM_CK/LCD_COM2 | UP/DOWN |
| 6 | PB_21 | | | I/O GPIO, input, high impedance | | UART0_RTS/PCM_SYNC/LCD_COM1 | UP/DOWN |
| 7 | PB_20 | | | I/O UART_RX | | UART0_RX/PWM1/UART1_CTS/I2C_SCL | UP/DOWN |
| 8 | PB_19 | | | I/O UART_TX | | UART0_TX / PWM0 / UART1_RTS / I2C_SDA | UP/DOWN |
| 9 | WAKEUP | I | WAKEUP | wakeup function | | | DOWN |
| 10 | RESET | | | I RESET | reset | | UP |
| 11 | XTAL_OUT | O | External | crystal oscillator output | | | |
| 12 | XTAL_IN | I | External | crystal input | | | |
| 13 | VDD33 | | | P chip power supply, 3.3V | | | |
| 14 | NC | | | | | | |
| 15 | VDD33 | | | P chip power supply, 3.3V | | | |
| 16 | VDD33 | | | P chip power supply, 3.3V | | | |
| 17 | VDD33 | | | P chip power supply, 3.3V | | | |
| 18 | BOOTMODE | I/O | BOOTMODE | | | I2S_MCLK/LSPI_CS/PWM2/I2S_DO | UP/DOWN |
| 19 | PA_1 | | | I / O JTAG_CK | | JTAG_CK/I2C_SCL/PWM3/I2S_LRCK/ADC_1 | UP/DOWN |
| 20 | PA_2 | | | I/O GPIO, input, high impedance | | UART1_RTS/UART2_TX/PWM0/UART3_RTS/ADC_4 | UP/DOWN |
| 21 | PA_3 | | | I/O GPIO, input, high impedance | | UART1_CTS/UART2_RX/PWM1/UART3_CTS/ADC_3 | UP/DOWN |
| 22 | PA_4 | | | I / O JTAG_SWO | | JTAG_SWO/I2C_SDA/PWM4/I2S_BCK/ADC_2 | UP/DOWN |
| 23 | PA_5 | | | I/O GPIO, input, high impedance | | UART3_TX/UART2_RTS/PWM_BREAK/UART4_RTS | UP/DOWN |
| 24 | PA_6 | | | I/O GPIO, input, high impedance | | UART3_RX/UART2_CTS/NULL/UART4_CTS/LCD_SEG31 | UP/DOWN |
| 25 | PA_7 | | | I/O GPIO, input, high impedance | | PWM4/LSPI_MOSI/I2S_MCK/I2S_DI/LCD_SEG3/Touch_1 | UP/DOWN |
| 26 | PA_8 | | | I/O GPIO, input, high impedance | | PWM_BREAK/UART4_TX/UART5_TX/I2S_BCLK/LCD_SEG4 | UP/DOWN |
| 27 | PA_9 | | | I/O GPIO, input, high impedance | | MMC_CLK/UART4_RX/UART5_RX/I2S_LRCLK/LCD_SEG5/TOUCH_2 | UP/DOWN |
| 28 | PA_10 | | | I/O GPIO, input, high impedance | | MMC_CMD/UART4_RTS/PWM0/I2S_DO/LCD_SEG6/TOUCH_3 | UP/DOWN |
| 29 | VDD33 | | | P chip power supply, 3.3V | | | |
| 30 | PA_11 | | | I/O GPIO, input, high impedance | | MMC_DAT0/UART4_CTS/PWM1/I2S_DI/LCD_SEG7 | UP/DOWN |
| 31 | PA_12 | | | I/O GPIO, input, high impedance | | MMC_DAT1/UART5_TX/PWM2/LCD_SEG8/TOUCH_14 | UP/DOWN |
| 32 | PA_13 | | | I/O GPIO, input, high impedance | | MMC_DAT2/UART5_RX/PWM3/LCD_SEG9 | UP/DOWN |

| | | | | |
|----|-------|---------------------------------|---|---------|
| 33 | PA_14 | I/O GPIO, input, high impedance | MMC_DAT3/UART5_CTS/PWM4/LCD_SEG10/TOUCH_15 | UP/DOWN |
| 34 | PA_15 | I/O GPIO, input, high impedance | PSRAM_CK/UART5_RTS/PWM_BREAK/LCD_SEG11 | UP/DOWN |
| 35 | PB_0 | I/O GPIO, input, high impedance | PWM0/LSPI_MISO/UART3_TX/PSRAM_CK/LCD_SEG12/Touch_4 | UP/DOWN |
| 36 | PB_1 | I/O GPIO, input, high impedance | PWM1/LSPI_CK/UART3_RX/PSRAM_CS/LCD_SEG13/Touch_5 | UP/DOWN |
| 37 | PB_2 | I/O GPIO, input, high impedance | PWM2/LSPI_CK/UART2_TX/PSRAM_D0/LCD_SEG14/Touch_6 | UP/DOWN |
| 38 | PB_3 | I/O GPIO, input, high impedance | PWM3/LSPI_MISO/UART2_RX/PSRAM_D1/LCD_SEG15/Touch_7 | UP/DOWN |
| 39 | PB_27 | I/O GPIO, input, high impedance | PSRAM_CS/UART0_TX/LCD_COM3 | UP/DOWN |
| 40 | PB_4 | I/O GPIO, input, high impedance | LSPI_CS/UART2_RTS/UART4_TX/PSRAM_D2/LCD_SEG16/Touch_8 | UP/DOWN |
| 41 | PB_5 | I/O GPIO, input, high impedance | LSPI_MOSI/UART2_CTS/UART4_RX/PSRAM_D3/LCD_SEG17/Touch_9 | UP/DOWN |
| 42 | VDD33 | P chip power supply, 3.3V | | |
| 43 | CAP | I External capacitor, 1μF | | |
| 44 | PB_6 | I/O GPIO, input, high impedance | UART1_TX/MMC_CLK/HSPI_CK/SDIO_CK/LCD_SEG18/Touch_10 | UP/DOWN |
| 45 | PB_7 | I/O GPIO, input, high impedance | UART1_RX/MMC_CMD/HSPI_INT/SDIO_CMD/LCD_SEG19/Touch_11 | UP/DOWN |
| 46 | PB_8 | I/O GPIO, input, high impedance | I2S_BCK/MMC_D0/PWM_BREAK/SDIO_D0/LCD_SEG20/Touch_12 | UP/DOWN |
| 47 | PB_9 | I/O GPIO, input, high impedance | I2S_LRCK/MMC_D1/HSPI_CS/SDIO_D1/LCD_SEG21/Touch_13 | UP/DOWN |
| 48 | PB_12 | I/O GPIO, input, high impedance | HSPI_CK/PWM0/UART5_CTS/I2S_BCLK/LCD_SEG24 | UP/DOWN |
| 49 | PB_13 | I/O GPIO, input, high impedance | HSPI_INT/PWM1/UART5_RTS/I2S_LRCLK/LCD_SEG25 | UP/DOWN |
| 50 | PB_14 | I/O GPIO, input, high impedance | HSPI_CS/PWM2/LSPI_CS/I2S_DO/LCD_SEG26 | UP/DOWN |
| 51 | PB_15 | I/O GPIO, input, high impedance | HSPI_DI/PWM3/LSPI_CK/I2S_DI/LCD_SEG27 | UP/DOWN |
| 52 | PB_10 | I/O GPIO, input, high impedance | I2S_DI/MMC_D2/HSPI_DI/SDIO_D2/LCD_SEG22 | UP/DOWN |
| 53 | VDD33 | P chip power supply, 3.3V | | |
| 54 | PB_11 | I/O GPIO, input, high impedance | I2S_DO/MMC_D3/HSPI_DO/SDIO_D3/LCD_SEG23 | UP/DOWN |
| 55 | PB_16 | I/O GPIO, input, high impedance | HSPI_DO/PWM4/LSPI_MISO/UART1_RX/LCD_SEG28 | UP/DOWN |
| 56 | PB_17 | I/O GPIO, input, high impedance | UART5_RX/PWM_BREAK/LSPI_MOSI/I2S_MCLK/LCD_SEG29 | UP/DOWN |

Notes: 1. I = Input, O = Output, P = Power

6 Electrical Characteristics

6.1 Limit parameters

Table 7-1 Limit parameters

| parameter | name | minimum | Typical value | maximum value | unit |
|---------------------------------|------------------|--------------------|---------------|---------------------|------|
| Supply voltage | VDD | 3.0 | 3.3 | 3.6 | V |
| Input logic level low | V _{IL} | -0.3 | | 0.8 | V |
| Input logic level high | V _{IH} | 2.0 | | VDD+0.3 | V |
| Input pin capacitance | C _{pad} | | | 2 | pF |
| output logic level low | V _{OL} | | | 0.4 | V |
| output logic level high | V _{OH} | 2.4 | | | V |
| Output maximum drive capability | I _{MAX} | | | 24 | mA |
| Storage temperature range | T _{STR} | -40 [°] C | | +125 [°] C | °C |
| range of working temperature | T _{OPR} | -40 [°] C | | +85 [°] C | °C |

7 Package Information

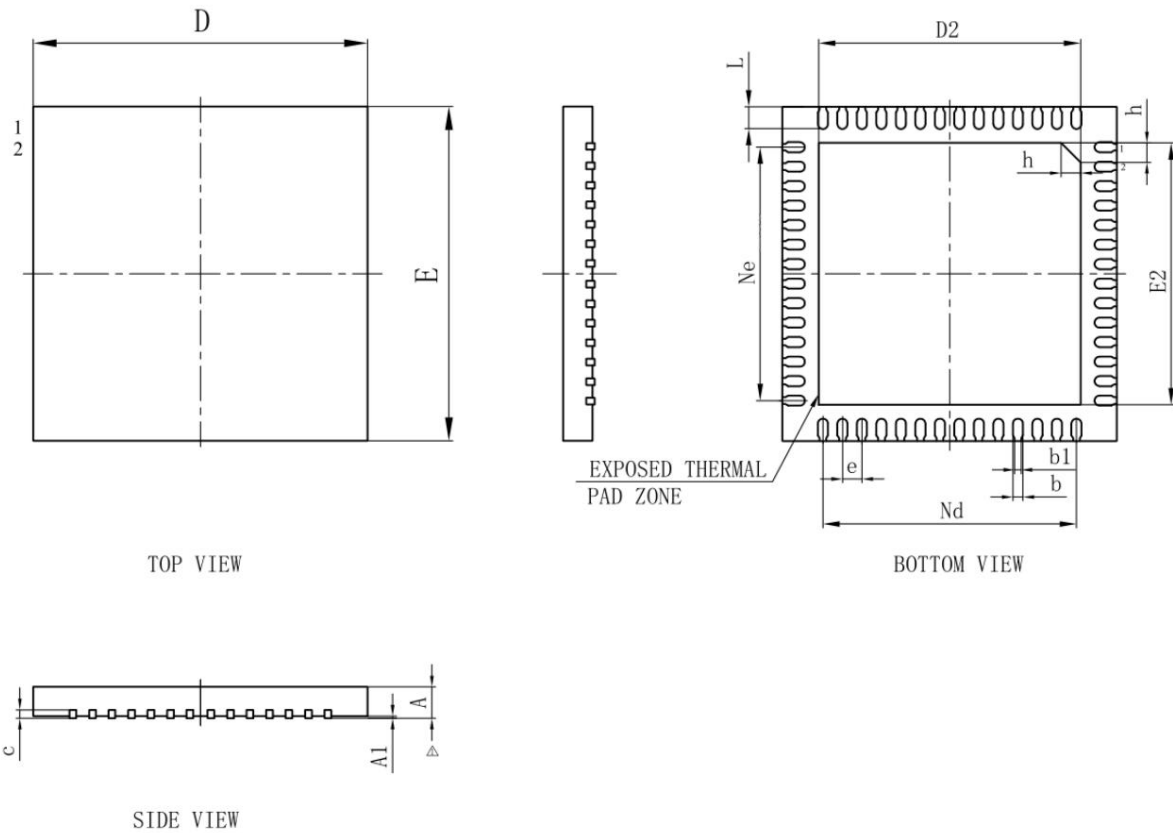

Figure 8-1 W806 Package Parameters

Table 8-1 W806 Package Parameters

| SYMBOL | MILLIMETER | | |
|--------|------------|------|------|
| | MIN | NAME | MAX |
| A | 0.70 | 0.75 | 0.80 |
| | 0.80 | 0.85 | 0.90 |
| A1 | 0.00 | 0.02 | 0.05 |
| b | 0.13 | 0.18 | 0.23 |
| b1 | 0.12REF | | |

| | | | |
|------------------|---------|------|------|
| c | 0.18 | 0.20 | 0.25 |
| D | 5.90 | 6.00 | 6.10 |
| D2 | 4.60 | 4.70 | 4.80 |
| And | 0.35BSC | | |
| Born | 4.55BSC | | |
| Nd | 4.55BSC | | |
| AND | 5.90 | 6.00 | 6.10 |
| E2 | 4.60 | 4.70 | 4.70 |
| I | 0.35 | 0.40 | 0.45 |
| h | 0.30 | 0.35 | 0.40 |
| L/F carrier size | 193x193 | | |